

# KIDDE™

## COMMERCIAL

FIRE ALARM SYSTEMS.  
POWERED BY PARTNERSHIP.\*

## UNIVERSAL INPUT- OUTPUT MODULE MOTHERBOARDS

### GSA-UIO2R, GSA-UIO6R

ELECTRONIC

Compatible with VS &amp; VM control systems

ADDRESSING

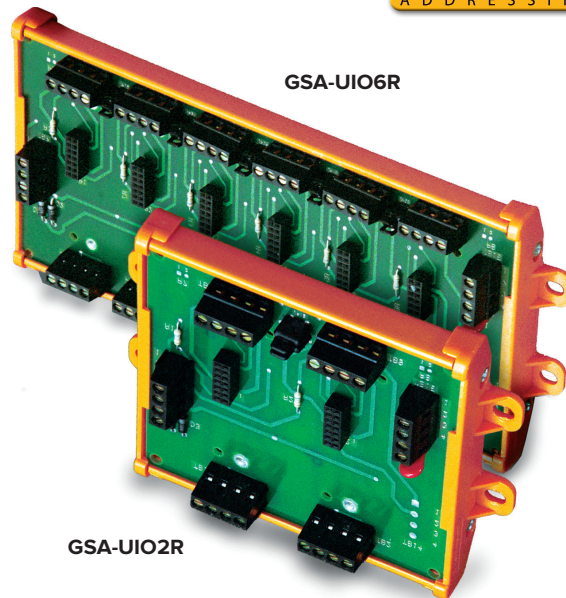

GSA-UIO6R

GSA-UIO2R



## OVERVIEW

Signature Series Universal Input-Output Module Motherboards provide mounting and wiring terminations for up to six Signature Series plug-in UIO (GSA-“M” series) modules. UIO motherboards slide into a rigid extruded track (included) with mounting pads for convenient mounting into a variety of equipment enclosures. UIO modules plug into the board and are held securely in place with captive machine screws. All field wiring connects to terminal blocks on the motherboard, which permits rapid removal and replacement of modules for troubleshooting.

The GSA-UIO2R provides mounting and wiring terminations for up to two UIO modules, and the GSA-UIO6R provides mounting and wiring terminations for up to six UIO modules. Both motherboards feature a riser #1 input and a riser #2 input bus. Jumpers on riser #1 input, between modules, facilitate sharing a single riser among more than one module. This significantly reduces wiring requirements. Removing the jumpers provide separate riser inputs to each adjacent module. Riser #2 input is fixed to each module position and cannot be split.

The GSA-UIO6 provides mounting and wiring terminations for up to six UIO modules. This motherboard provides two riser inputs that are common to all modules.

## STANDARD FEATURES

### Modular flexibility

Wide assortment of multi-function plug-in modules provides total flexibility.

### Minimum wiring requirements

Integral jumpers between modules allow sharing of risers to reduce installation wiring.

### Easy installation

#12 AWG (2.5 mm<sup>2</sup>) terminal blocks and sturdy mounting pads ensure quick installation into Kidde enclosures.

### Supports automatic device mapping

All compatible UIO modules transmit information to the loop controller regarding their circuit locations with respect to other Signature devices on the wire loop.

### Supports intelligent devices

On-board modules make decisions and input an alarm from initiating devices connected to them even if the loop controller's polling interrogation stops.

### Twisted or shielded wire not required

Because all decisions are made at the on-board modules, lower communication speeds are possible. This results in substantially improved control panel response time and less sensitivity to line noise and loop wiring properties.

### Supports electronic addressing

Programmable addresses are downloaded to compatible UIO modules from the loop controller, a PC, or the SIGA-PRO Signature Program/Service Tool. There are no switches or dials to set.

\*Kidde Commercial and its authorized resellers/distributors are separate and independent entities. This relationship between vendor and reseller/distributor does not constitute a legal partnership or create any shared liability between companies.

## MOUNTING AND INSTALLATION

Mount the UIO motherboard inside an MFC-A cabinet or other suitable electrical enclosure with screws and washers provided. Each MFC-A will hold one UIO2R motherboard or one UIO6 or UIO6R motherboard complete with their full complement of modules.

Plug a Signature Series UIO module into any available position on the motherboard and secure the module to the motherboard with the captive screws. Wiring connections are made to the terminals on the motherboard (see wiring diagram). UIO motherboard terminals are suited for #12 to #18 AWG (2.5 mm<sup>2</sup> to 0.75 mm<sup>2</sup>) wire size.

Kidde recommends that all boards and modules be installed according to latest recognized edition of national and local fire alarm codes.

## TESTING & MAINTENANCE

The module's automatic self-diagnosis identifies when it is defective and causes a trouble message. The user-friendly maintenance program shows the current state of each module and other pertinent messages. Single modules may be turned off (de-activated) temporarily, from the control panel.

Scheduled maintenance (Regular or Selected) for proper system operation should be planned to meet the requirements of the Authority Having Jurisdiction (AHJ). Refer to current NFPA 72 and ULC CAN/ULC 536 standards.

## COMPATIBILITY

Signature Series Universal Input/Output Module Boards are compatible only with GSA-“M” Series I/O Modules, which require a Signature Data Controller.

## WARNINGS & CAUTIONS

Signature devices will not operate without electrical power. As fires frequently cause power interruption, we suggest you discuss further safeguards with your fire protection specialist.

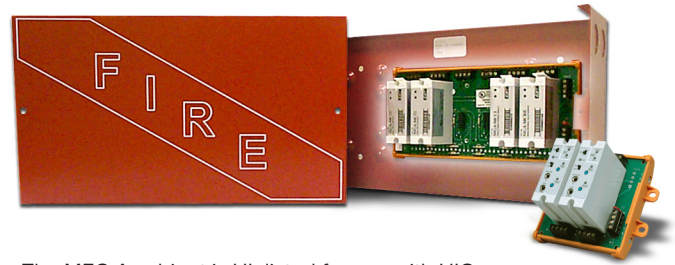

The MFC-A cabinet is UL listed for use with UIO motherboards and meets requirements for spacing and clearance around the components.

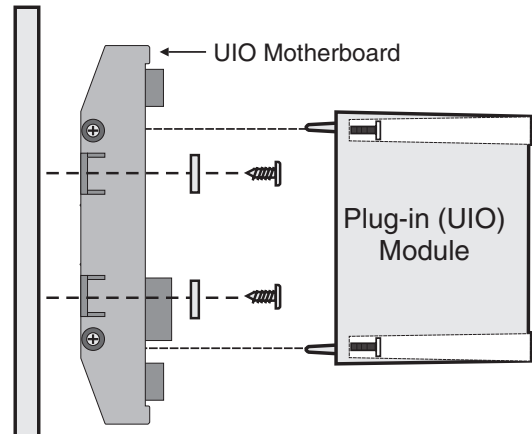

# TYPICAL WIRING

Signature Series Universal Input/Output Motherboards have terminal blocks to accept #18 AWG (0.75mm<sup>2</sup>), #16 AWG (1.0mm<sup>2</sup>), #14 AWG (1.5mm<sup>2</sup>), and #12 AWG (2.5mm<sup>2</sup>) wire sizes. See Signature Data Controller catalog sheets for detailed wiring requirements and specifications.

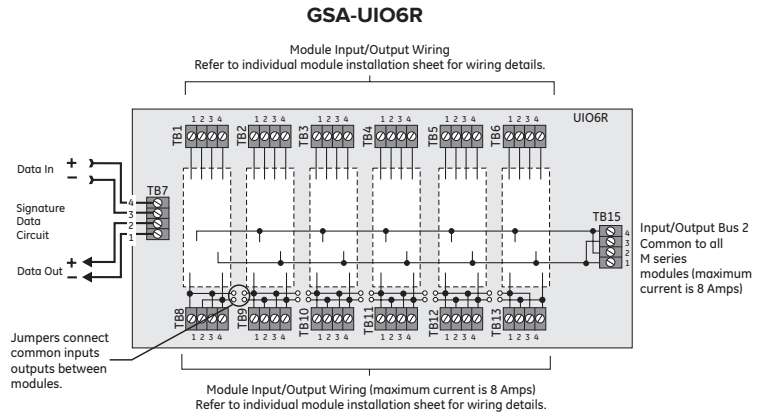
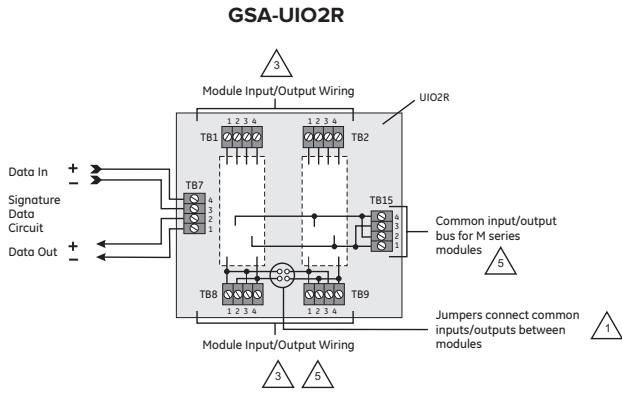

**Notes:**

- 1 Jumpers may be used to make the inputs/outputs between modules common.
- 2 Not all modules use the GSA-UIO2R terminals for the same functions.
- 3 Refer to individual GSA-M series installation sheets for jumper settings and wiring information. Installations with multiple SIGA-UIO motherboards or enclosures (which include other wiring) require FPL, FPLR, FPLP, or equivalent NEC-approved wire for all power limited wiring. Observe the details of supervision and power limited versus non-power limited circuits. Refer to the GSA-M series installation sheets.
- 4 Do not mix incompatible signals.
- 5 Maximum current is 8 Amps.
- 7 Refer to Signature Data Controller Installation Sheets for wiring specifications.

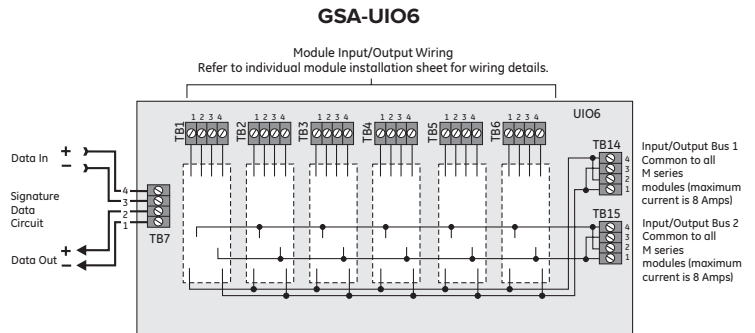



FIRE ALARM SYSTEMS.  
POWERED BY PARTNERSHIP.\*

## CONTACT US

Phone: 888.244.9979 (Option 4)  
Email: [kidde.fire@kgsolutions.com](mailto:kidde.fire@kgsolutions.com)  
Website: [kidde-esfire.com](http://kidde-esfire.com)

8985 Town Center Pkwy,  
Bradenton, FL 34202

©2025 Walter Kidde Portable Equipment, LLC  
All rights reserved.

\*Kidde Commercial and its authorized resellers/  
distributors are separate and independent entities.  
This relationship between vendor and reseller/  
distributor does not constitute a legal partnership  
or create any shared liability between companies.

## SPECIFICATIONS

Catalog Number	GSA-UIO2R	GSA-UIO6R	GSA-UIO6
Module Capacity	Two	Six	Six
Dimensions (with module installed)	5.4 inch L (across mounting feet) x 4.3 inch W x 3.2 inch H	9.56 inch L (across mounting feet) x 4.3 inch W x 3.2 inch H	
Address Requirements	no address required		
Type Code	none		
Compatible Modules	All GSA-Mxxx Signature Series		
Operating Voltage	15.2 to 19.95 Vdc (19 Vdc nominal)		
Mounting (cabinets)	Directly into suitable enclosures (e.g.: MFC-A) - Notes 1, 2, 3.		
Wiring Terminals	#12 AWG (2.5mm <sup>2</sup> ) to #18 AWG (0.75mm <sup>2</sup> )		
Storage and Operating Environment	Operating Temperature: 32°F to 120°F (0°C to 49°C) Storage Temperature: -4°F to 140°F (-20°C to 60°C) Operating and Storage Humidity: 0 to 93% RH		
Agency Listing	UL, ULC, MEA, CSFM		

### Notes:

1. Allow a minimum clearance of one inch around all sides of the UIO motherboard.
2. On-site drilling of mounting holes may be required. Self-tapping mounting screws are provided.
3. Suitable cabinets: MFC-A, 2-WB, 2-WB3, 2-WB7, CAB2, 3-CAB5, 3-CAB7, 3-CAB14, 3-CAB21, 3-RCC series, RACC series.

## ORDERING INFORMATION

Catalog Number	Description	Ship Wt. - lb (kg)
GSA-UIO2R	Universal Input-Output Module Board w/Riser Inputs - Two Module Positions	0.32 (0.15)
GSA-UIO6R	Universal Input-Output Module Board w/Riser Inputs - Six Module Positions	0.62 (0.28)
GSA-UIO6	Universal Input-Output Module Board - Six Module Positions	0.56 (0.25)
MFC-A	UL listed cabinet for mounting UIO motherboards, red with white "FIRE" 8 inch H X 14 inch W X 3.5 inch D (203 mmH X 356 mm W X 89 mm D)	7.0 (3.1)