

# KIDDE™

## COMMERCIAL

FIRE ALARM SYSTEMS.  
POWERED BY PARTNERSHIP.\*

## CONTROL RELAY MODULES

GSA-CR, GSA-MCR, GSA-CRR,  
GSA-MCRR

### OVERVIEW

The Control Relay Module and the Polarity Reversal Relay Module are part of the Signature Series system. They are intelligent analog addressable devices available in either plug-in (UIO) versions, or standard 1-gang mount versions.

The **GSA-CR/MCR** Control Relay Module provides a Form “C” dry relay contact to control external appliances such as door closers, fans, dampers etc. This device does not provide supervision of the state of the relay contact. Instead, the on-board microprocessor ensures that the relay is in the proper ON/OFF state. Upon command from the loop controller, the GSA-CR/MCR relay activates the normally open or normally-closed contact.

The **GSA-CRR/MCRR** Polarity Reversal Relay Module provides a Form “C” dry relay contact to power and activate a series of GSA-AB4G Audible Sounder Bases. Upon command from the Signature loop controller, the GSA-CRR reverses the polarity of its 24 Vdc output, thus activating all Sounder Bases on the data loop.

**Standard-mount versions (GSA-CR and GSA-CRR)** are installed to standard North American 1-gang electrical boxes, making them ideal for locations where only one module is required. Separate I/O and data loop connections are made to each module.

**Plug-in UIO versions (GSA-MCR and GSA-MCRR)** are part of the UIO family of plug-in Signature Series modules. They function identically to the standard mount versions, but take advantage of the modular flexibility and easy installation that characterizes all UIO modules. Two- and six-module UIO motherboards are available. All wiring connections are made to terminal blocks on the motherboard. UIO assemblies may be mounted in Kidde enclosures.

\*Kidde Commercial and its authorized resellers/distributors are separate and independent entities. This relationship between vendor and reseller/distributor does not constitute a legal partnership or create any shared liability between companies.

ELECTRONIC

Compatible with VS &amp; VM control systems

ADDRESSING

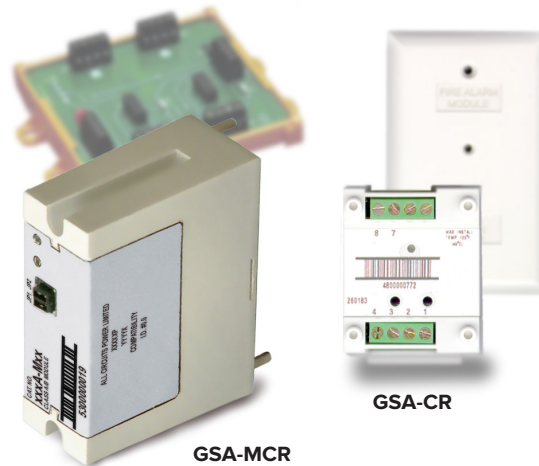

GSA-MCR

GSA-CR



### STANDARD FEATURES

#### Provides one no/nc contact (GSA-CR/MCR)

Form “C” dry relay contact can be used to control external appliances such as door closers, fans, dampers etc.

#### Allows group operation of sounder bases

The GSA-CRR/MCRR reverses the polarity of its 24 Vdc output, thus activating all Sounder Bases on the data loop.

#### Plug-in (UIO) or standard 1-gang mount

UIO versions allow quick installation where multiple modules are required. The 1-gang mount version is ideal for remote locations that require a single module.

#### Automatic device mapping

Signature modules transmit information to the loop controller regarding their circuit locations with respect to other Signature devices on the wire loop.

#### Electronic addressing

Programmable addresses are downloaded from the loop controller, a PC, or the SIGA-PRO Signature Program/Service Tool; there are no switches or dials to set.

#### Intelligent device with microprocessor

All decisions are made at the module to allow lower communication speed with substantially improved control panel response time and less sensitivity to line noise and loop wiring properties; twisted or shielded wire is not required.

#### Ground fault detection by address

Detects ground faults right down to the device level.

## INSTALLATION

**GSA-CR and GSA-CRR:** modules mount to North American 2½ inch (64 mm) deep 1-gang boxes and 1½ inch (38 mm) deep 4 inch square boxes with 1-gang covers and GSA-MP mounting plates. The terminals are suited for #12 to #18 AWG (2.5 mm<sup>2</sup> to 0.75 mm<sup>2</sup>) wire size.

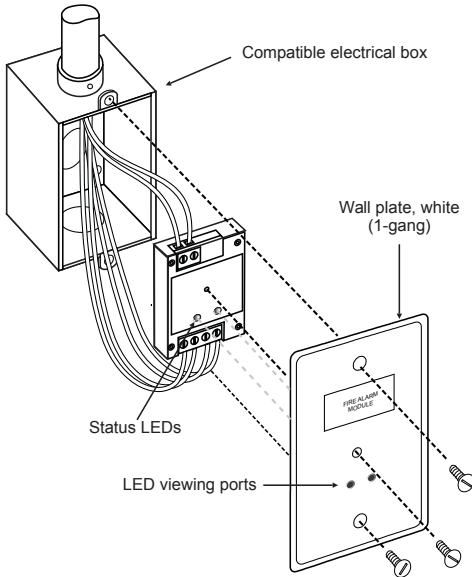

**GSA-MCR and GSA-MCRR:** mount the UIO motherboard inside a suitable Kidde enclosure with screws and washers provided. Plug the module into any available position on the motherboard and secure the module to the motherboard with the captive screws. Wiring connections are made to the terminals on the motherboard (see wiring diagram). UIO motherboard terminals are suited for #12 to #18 AWG (2.5 mm<sup>2</sup> to 0.75 mm<sup>2</sup>) wire size.

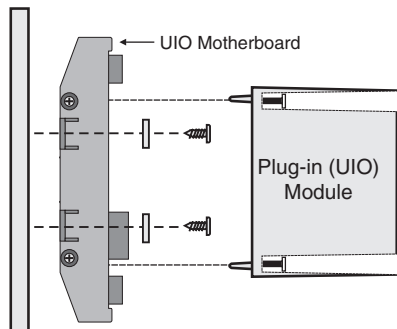

**Electronic Addressing** – The loop controller electronically addresses each module, saving valuable time during system commissioning. Setting complicated switches or dials is not required. Each module has its own unique serial number stored in its on-board memory. The loop controller identifies each device on the loop and assigns a “soft” address to each serial number. If desired, the modules can be addressed using the SIGA-PRO Signature Program/Service Tool.

Kidde recommends that this module be installed according to latest recognized edition of national and local fire alarm codes.

## APPLICATION

The operation of Signature Series control relays is determined by their sub-type code or “Personality Code.”

**Personality Code 8: CONTROL RELAY (GSA-CR/MCR) - Dry Contact Output.** This setting configures the module to provide one Form “C” DRY RELAY CONTACT to control Door Closers, Fans, Dampers, etc. Contact rating is 2.0 amp @ 24 Vdc; 0.5 amp @ 120 Vac (or 0.25A @ 220 Vac for non-UL applications). Personality Code 8 is assigned at the factory. No user configuration is required.

**Personality Code 8: POLARITY REVERSAL RELAY MODULE (GSA-CRR/MCRR).** This setting configures the module to reverse the polarity of its 24 Vdc output. Contact rating is 2.0 amp @ 24 Vdc (pilot duty). Personality Code 8 is assigned at the factory. No user configuration is required.

## COMPATIBILITY

These modules are part of Kidde’s Signature Series intelligent processing and control platform. They are compatible with VM, and VS Series control panels.

## WARNINGS & CAUTIONS

This module will not operate without electrical power. As fires frequently cause power interruption, we suggest you discuss further safeguards with your local fire protection specialist.

## TESTING & MAINTENANCE

The module’s automatic self-diagnosis identifies when it is defective and causes a trouble message. The user-friendly maintenance program shows the current state of each module and other pertinent messages. Single modules may be turned off (deactivated) temporarily, from the control panel. Availability of maintenance features is dependent on the fire alarm system used. Scheduled maintenance (Regular or Selected) for proper system operation should be planned to meet the requirements of the Authority Having Jurisdiction (AHJ). Refer to current NFPA 72 and ULC CAN/ULC 536 standards.

# TYPICAL WIRING

Modules will accept #18 AWG (0.75mm<sup>2</sup>), #16 (1.0mm<sup>2</sup>), #14 AWG (1.50mm<sup>2</sup>) and #12 AWG (2.5mm<sup>2</sup>) wire sizes.

Note: Sizes #16 AWG (1.0mm<sup>2</sup>) and #18 AWG (0.75mm<sup>2</sup>) are preferred for ease of installation. See Signature Loop Controller catalog sheet for detailed wiring requirement specifications.

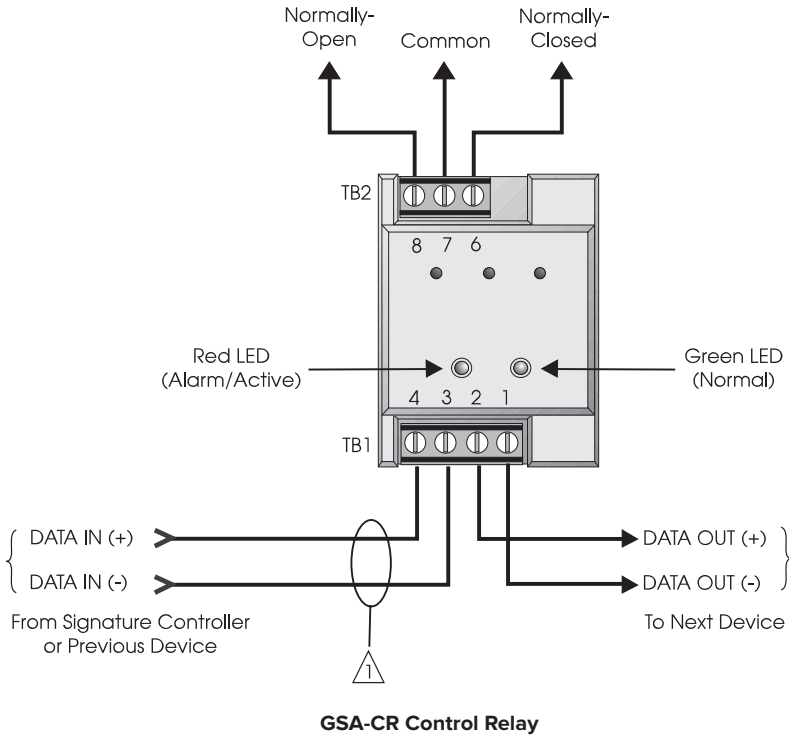

**GSA-CR Control Relay**

**Notes:**

- 1 Refer to Signature Loop Controller Installation Sheet for wiring specifications.
- 2 NFPA 72 requires that the GSA-CR/GSA-MCR be installed in the same room as the device it is controlling. This requirement may not apply in all markets. Check with your local AHJ for details.
- 3 The GSA-UIO6R and the GSA-UIO2R do not come with TB14.
- 4 The GSA-UIO6 does not come with TB8 through TB13.
- 5 Supervised and power-limited.
- 6 If the source is nonpower-limited, maintain a space of 1/4 inch from power-limited wiring or use FPL, FPLP, FPLR, or an equivalent in accordance with the National Electrical Code.
- 7 Maximum #12 AWG (2.5mm<sup>2</sup>) wire. Min. #18 (0.75mm<sup>2</sup>).

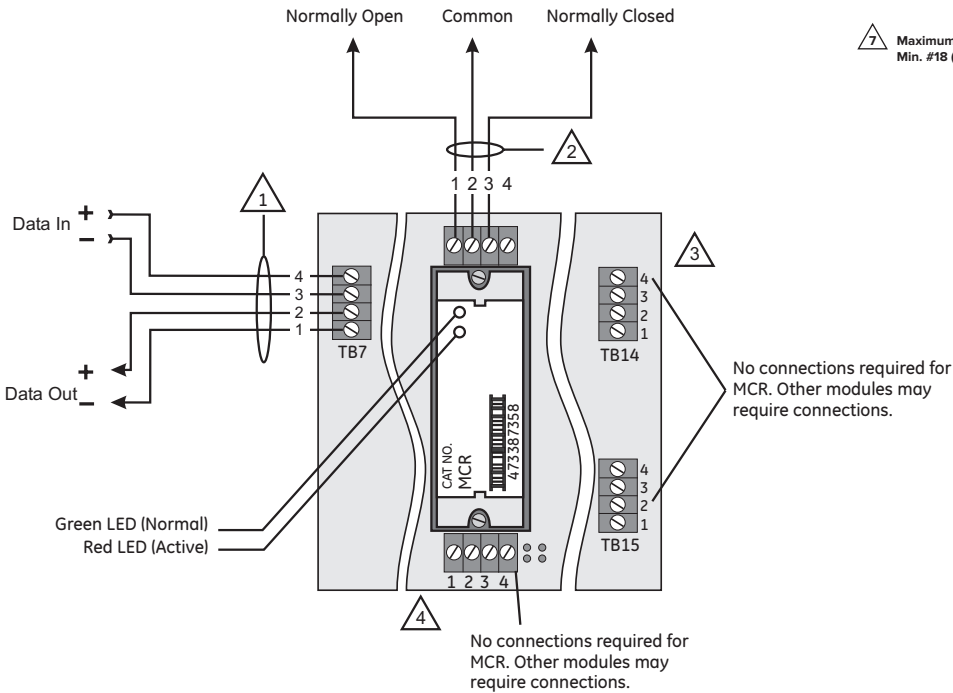

**GSA-MCR Control Relay**

# TYPICAL WIRING

Modules will accept #18 AWG (0.75mm<sup>2</sup>), #16 (1.0mm<sup>2</sup>), #14 AWG (1.50mm<sup>2</sup>) and #12 AWG (2.50mm<sup>2</sup>) wire sizes.

Note: Sizes #16 AWG (1.0mm<sup>2</sup>) and #18 AWG (0.75mm<sup>2</sup>) are preferred for ease of installation. See Signature Loop Controller catalog sheet for detailed wiring requirement specifications.

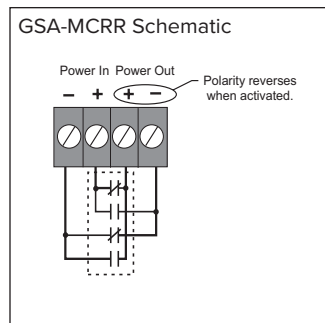
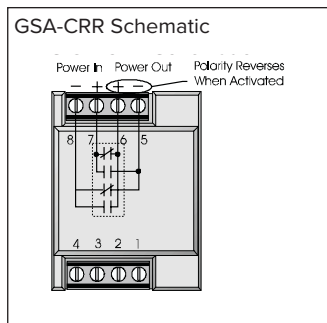
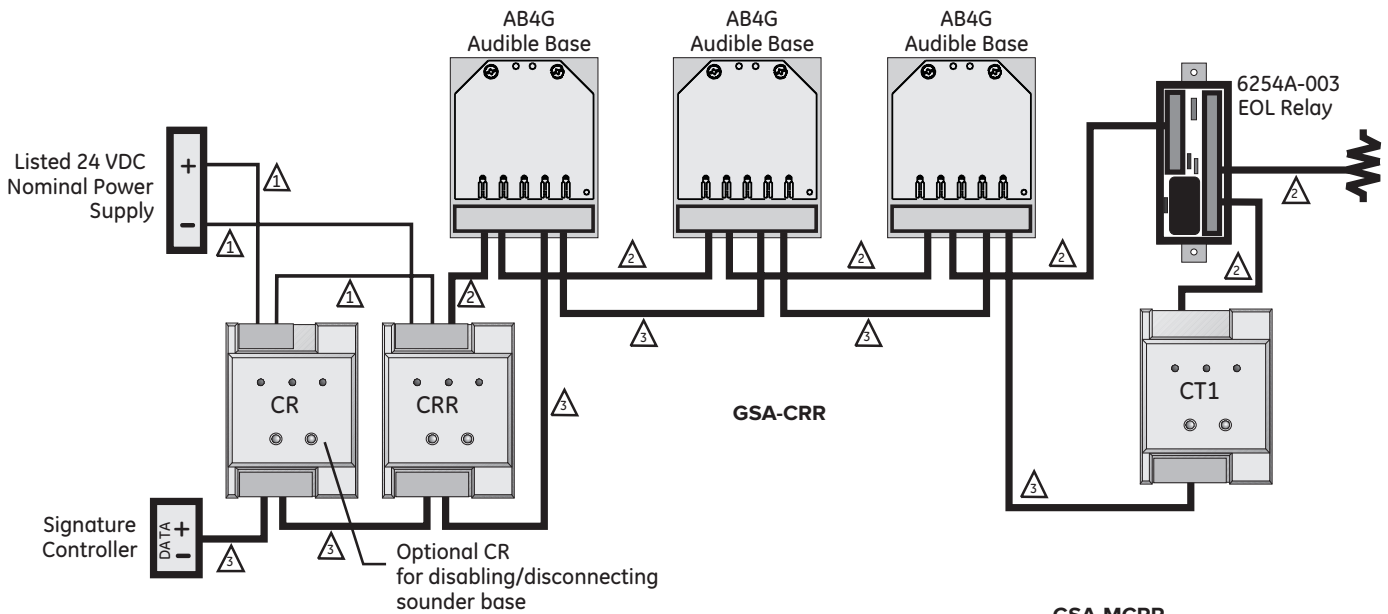

**Notes:**

- 1 Refer to the Signature controller installation sheet for wiring.
- 2 One Pair of Wires (24 Vdc power).
- 3 One Pair of Wires (Signature Data).
- 4 Single Wire (24 Vdc power).
- 5 The GSA-UIO6R and the GSA-UIO2R do not come with TB14.
- 6 The GSA-UIO6 does not come with TB8 through TB13.
- 7 Supervised and power-limited.
- 8 If the source is nonpower-limited, maintain a space of 1/4 inch from power-limited wiring or use FPL, FPLP, FPLR, or an equivalent in accordance with the National Electrical Code.
- 9 Maximum #12 AWG (2.5 mm<sup>2</sup>) wire; Minimum #18 AWG (0.75 mm<sup>2</sup>).
- 10 End-of-Line Relay must monitor and report power supply trouble to control panel.
- 11 Class B Data wiring may be "T-tapped."

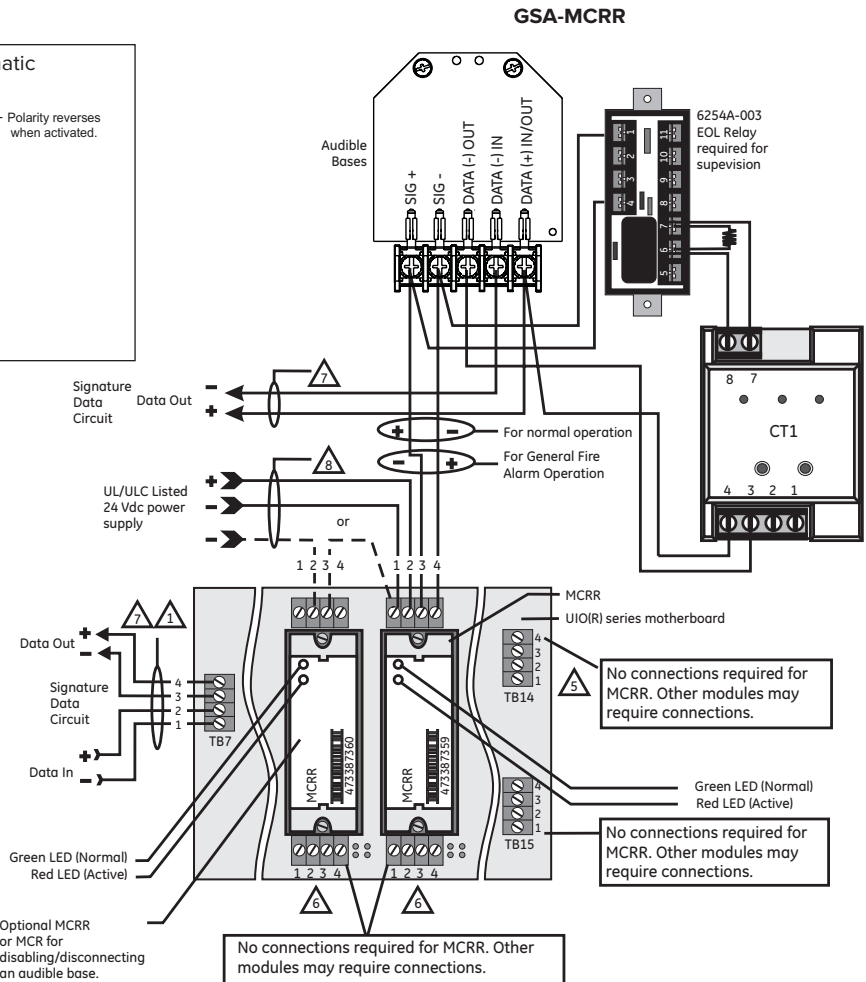

## SPECIFICATIONS

Catalog Number	GSA-CR	GSA-MCR	GSA-CRR	GSA-MCRR
Description	Control Relay		Polarity Reversal Relay	
Type Code	Personality Code 8 (Factory Set)		Personality Code 8 (Factory Set)	
Address Requirements	Uses 1 Module Address			
Operating Current	Standby = 75 $\mu$ A Activated = 75 $\mu$ A			
Operating Voltage	15.2 to 19.95 Vdc (19 Vdc nominal)			
Relay Type and Rating	Form C, 2 Amps @ 24 Vdc (pilot duty), 0.5 Amps @ 120 Vac and 0.25 Amps @ 220 Vac (220 Vac is non-UL). Not rated for capacitive loads.			
Mounting	North American 2½ inch (64 mm) deep 1-gang boxes and 1½ inch (38 mm) deep 4 inch square boxes with 1-gang covers and GSA-MP mounting plates	Plugs into UIO2R, UIO6R or UIO6 Motherboards	North American 2½ inch (64 mm) deep 1-gang boxes and 1½ inch (38 mm) deep 4 inch square boxes with 1-gang covers and GSA-MP mounting plates	Plugs into UIO2R, UIO6R or UIO6 Motherboards
Construction & Finish	High Impact Engineering Polymer			
Storage and Operating Environment	Operating Temperature: 32°F to 120°F (0°C to 49°C) Storage Temperature: -4°F to 140°F (-20°C to 60°C) Humidity: 0 to 93% RH			
LED Operation	On-board Green LED - Flashes when polled On-board Red LED - Flashes when in alarm/active			
Compatibility	Use With: Signature Loop Controller			
Agency Listings	UL, ULC, CSFM, MEA			

## ORDERING INFORMATION

Catalog Number	Description	Ship Weight - lbs (kg)
GSA-CR	Control Relay Module (Standard Mount)	0.4 (0.15)
GSA-MCR	Control Relay Module (UIO Mount)	0.18 (0.08)
GSA-CRR	Polarity Reversal Relay Module (Standard Mount)	0.4 (0.15)
GSA-MCRR	Polarity Reversal Relay Module (UIO Mount)	0.18 (0.08)

### Related Equipment

27193-11	Surface Mount Box - Red, 1-gang	1 (0.6)
27193-16	Surface Mount Box - White, 1-gang	1 (0.6)
GSA-UIO2R	Universal Input-Output Module Board w/Riser Inputs - Two Module Positions	0.32 (0.15)
GSA-UIO6R	Universal Input-Output Module Board w/Riser Inputs - Six Module Positions	0.62 (0.28)
GSA-UIO6	Universal Input-Output Module Board - Six Module Positions	0.56 (0.25)
GSA-AB4G	Audible (Sounder) Detector Base	0.3 (0.15)

### Accessories

MFC-A	Multifunction Fire Cabinet - Red, supports Signature Module Mounting Plates	7.0 (3.1)
GSA-MB4	Transponder Mounting Bracket (allows for mounting two 1-gang modules in a 2-gang box)	0.4 (0.15)
GSA-MP1	Signature Module Mounting Plate, 1 footprint	1.5 (0.70)
GSA-MP2	Signature Module Mounting Plate, 1/2 footprint	0.5 (0.23)
GSA-MP2L	Signature Module Mounting Plate, 1/2 extended footprint	1.02 (0.46)



FIRE ALARM SYSTEMS.  
POWERED BY PARTNERSHIP.\*

## CONTACT US

Phone: 888.244.9979 (Option 4)  
Email: [kidde.fire@kgsolutions.com](mailto:kidde.fire@kgsolutions.com)  
Website: [kidde-esfire.com](http://kidde-esfire.com)

8985 Town Center Pkwy,  
Bradenton, FL 34202

©2025 Walter Kidde Portable Equipment, LLC  
All rights reserved.

\*Kidde Commercial and its authorized resellers/  
distributors are separate and independent entities.  
This relationship between vendor and reseller/  
distributor does not constitute a legal partnership  
or create any shared liability between companies.

## SIGNATURE SERIES OVERVIEW

The Signature Series intelligent analog-addressable system from Kidde is an entire family of multi-sensor detectors and mounting bases, multiple-function input and output modules, network and non-network control panels, and user-friendly maintenance and service tools. Analog information from equipment connected to Signature devices is gathered and converted into digital signals. An onboard microprocessor in each Signature device measures and analyzes the signal and decides whether or not to input an alarm. The microprocessor in each Signature device provides four additional benefits – Self-diagnostics and History Log, Automatic Device Mapping, Stand-alone Operation and Fast, Stable Communication.

**Self-diagnostics and History Log** – Each Signature Series device constantly runs self-checks to provide important maintenance information. The results of the self-check are automatically updated and permanently stored in its non-volatile memory. This information is accessible for review any time at the control panel, PC, or using the SIGA-PRO Signature Program/Service Tool. The information stored in device memory includes:

- Device serial number, address, and type
- Time and date of last alarm
- Most recent trouble code logged by the detector – 32 possible trouble codes may be used to diagnose faults

**Automatic Device Mapping** – The Signature Data Controller (SDC) learns where each device's serial number address is installed relative to other devices on the circuit. The SDC keeps a map of all Signature Series devices connected to it. The Signature Series Data Entry Program also uses the mapping feature. With interactive menus and graphic support, the wired circuits between each device can be examined. Layout or "as-built" drawing information showing branch wiring (T-taps), device types and their address are stored on disk for printing hard copy. This takes the mystery out of the installation. The preparation of as-built drawings is fast and efficient.

Device mapping allows the Signature Data Controller to discover:

- Unexpected additional device addresses
- Missing device addresses
- Changes to the wiring in the circuit

Most Signature modules use a personality code selected by the installer to determine their actual function. Personality codes are downloaded from the SDC during system configuration and are indicated during device mapping.

**Standalone Operation** – A decentralized alarm decision by the device is guaranteed. Onboard intelligence permits the device to operate in standalone (degrade) mode. If Signature loop controller CPU communications fail for more than four seconds, all devices on that circuit go into standalone mode. The circuit acts like a conventional alarm receiving circuit. Each Signature device on the circuit continues to collect and analyze information from its slave devices. When connected to a panel utilizing standalone operation, modules with their "personality" set as alarm devices (IDC) will alarm should their slave alarm-initiating device activate.