

# KI-RB4 Detector Base Installation Sheet

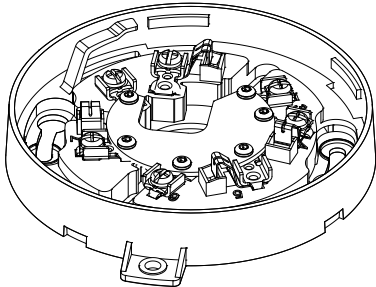

## Description

The KI-RB4 is a Signature Series detector base with outer mounting lugs for a 4-inch square box, and includes a GSA-TS trim skirt. The base connects the detector to the signaling line circuit (SLC), but does not support the GSA-LED. The KI-RB4 adds relay functionality to the listed compatible detectors.

## Installation

**Caution:** Risk of equipment damage. To prevent damage to the base, do not overtighten the base mounting screws or wire terminal screws. Refer to “Specifications” on page 2 for torque values.

Refer to Technical Bulletin P/N 3102483-EN for location and spacing requirements.

### To install the KI-RB4:

1. Mount the KI-RB4 on a compatible electrical box using the screws provided with the electrical box.
2. Wire the base as shown in the “Wiring” section.
3. Write the address assigned to the detector on the label provided and apply the label to the inside rim of the base.
4. Install the GSA-TS trim skirt to finish the installation.

## Wiring

**Caution:** Risk of system failure. Electrical supervision requires that the wire run be broken at each terminal. Do not loop the field wires around the terminals.

### Notes

- Shielded wire is required only in environments with very high electrical noise.
- Shields, if used, must be continuous and insulated from ground.
- For Class B wiring, there is no shield connection to ground at the last device.

### To wire the KI-RB4:

1. Wire the detector base as shown in Figure 1, observing polarity.  
Break the wire run at each terminal. Do not loop the signaling line circuit field wires around the terminals.
2. Insulate the shield with electrical tape.

Figure 1: Wiring the KI-RB4

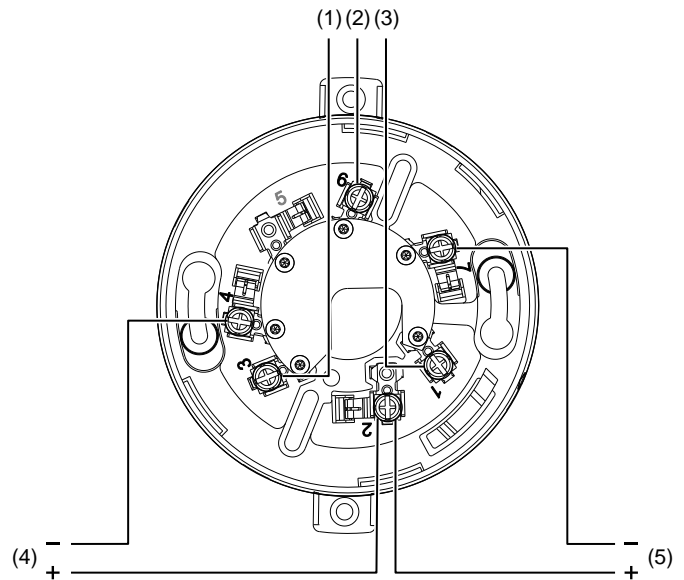

- (1) Common (terminal 3)
- (2) Normally closed (terminal 6)
- (3) Normally open (terminal 1)
- (4) SLC IN from previous device
- (5) SLC OUT to next device

Table 1: Base terminals

Number	Description	Number	Description
1	Normally open	5	Not used
2	SLC IN / OUT +	6	Normally closed
3	Common	7	SLC OUT -
4	SLC IN -		

KI-RB4



## Specifications

Contact rating	1.0 A at 30 VDC, pilot duty
Wire size	12 to 18 AWG (1.0 to 4.0 mm <sup>2</sup> ) Sizes 16 and 18 AWG are preferred
Screw torque	
Base mounting	18 lbf-in (2.0 N·m) max.
Terminal	12 lbf-in (1.4 N·m) max.
Housing	High impact engineering polymer, white
Compatible detectors	Signature Series detectors
Accessories	GSA-TS Four-Inch Box Trim Skirt/Ring
Compatible electrical boxes	North American single-gang box Octagon box 3-1/2 in. (89 mm) by 1-1/2 in. (38 mm) deep Octagon box 4 in. (102 mm) by 1-1/2 in. (38 mm) deep European single-gang box 75 mm with 60.3 mm fixing centers BESA box with 60.3 mm fixing centers Square box 4 in. (102 mm) by 1-1/2 in. (38 mm) deep (using the outer mounting lugs on the base)
Operating environment	
Temperature	32 to 120°F (0 to 49°C)
Relative humidity	0 to 93% noncondensing
Technical bulletin	P/N 3102483-EN

## Contact information

For contact information, see [www.kidde.com](http://www.kidde.com).

